

INSTALLATION INSTRUCTIONS

VOLVO L 70 C/D WHEEL LOADER

HAMMOND AIR CONDITIONING LTD
INGERSOLL, ONT.
1-800-267-2665
1-888-267-3745 (FAX)

VOLVO L 70 C/D INSTRUCTIONS

EVAPORATOR COIL:

The evaporator coil mounts in the side panel below the right hand window and is beside the heater coil. The assembly is complete with frame and drain pan in place.

1. Open the housing below the window and remove the filter and cover from the intake area.
2. Install the evaporator assembly in place with the self drilling screws provided to secure it to the heater assembly.
3. Use the adhesive backed foam provided to fill any air gaps.



Evaporator assembly in place with hoses run and thermostat probe in position.

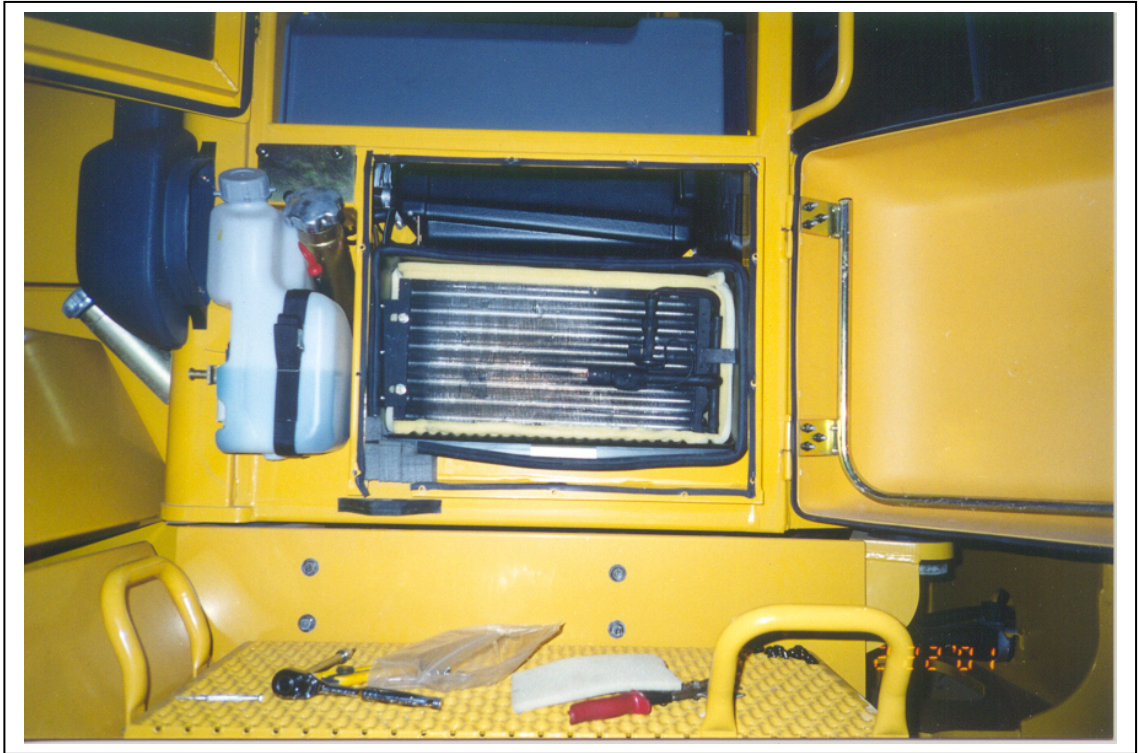

Face on view of evaporator .



End view of evaporator assembly in place.



Filter assembly in position with pre-filter in place.

COMPRESSOR:

The compressor mounts on the lower left side of the engine and drives off of the open pulley on the crankshaft. The compressor mount bolts on the factory mount point.

- 1) Install the compressor mount into location using the hardware provided. The bolt holes are in place and are threaded for the M10 bolts.
- 2) Install the compressor onto the mount using the hardware provided.
- 3) Install the front stiffener bracket from the inside of the compressor mount ear to the open threaded hole on the gear housing. Use the spacers supplied.
- 4) Install the drive belt and tighten. Check the belt alignment and adjust if necessary.

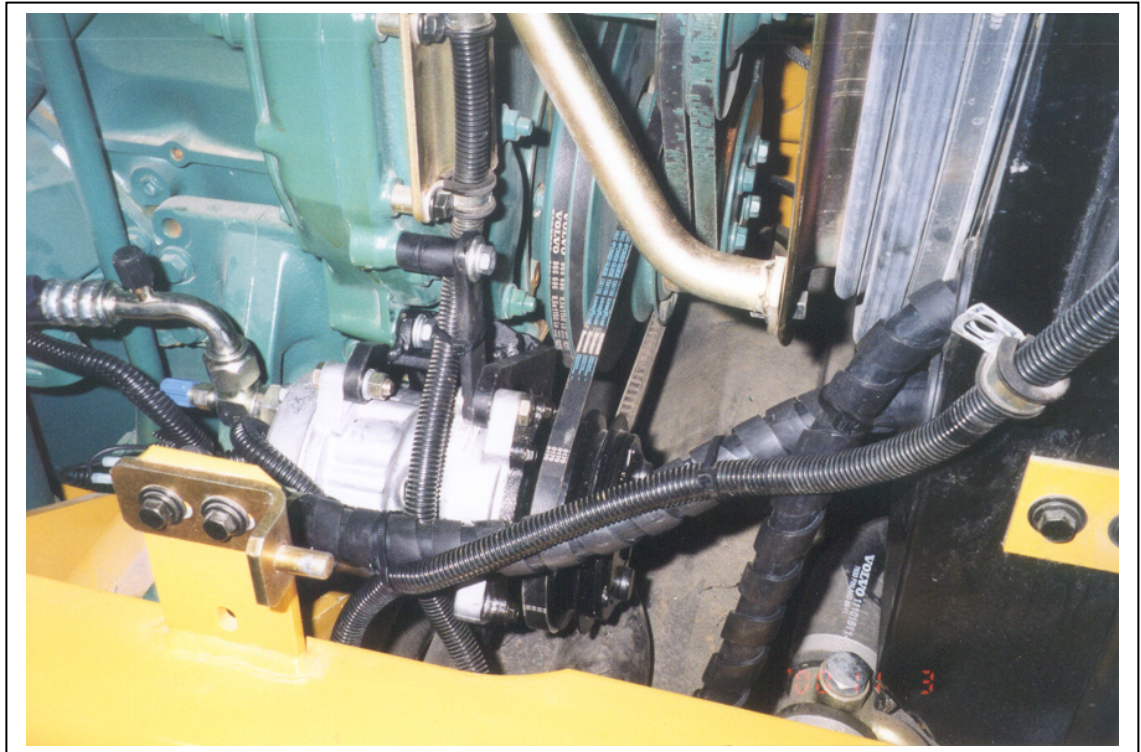

Compressor in place showing stiffener and belt.

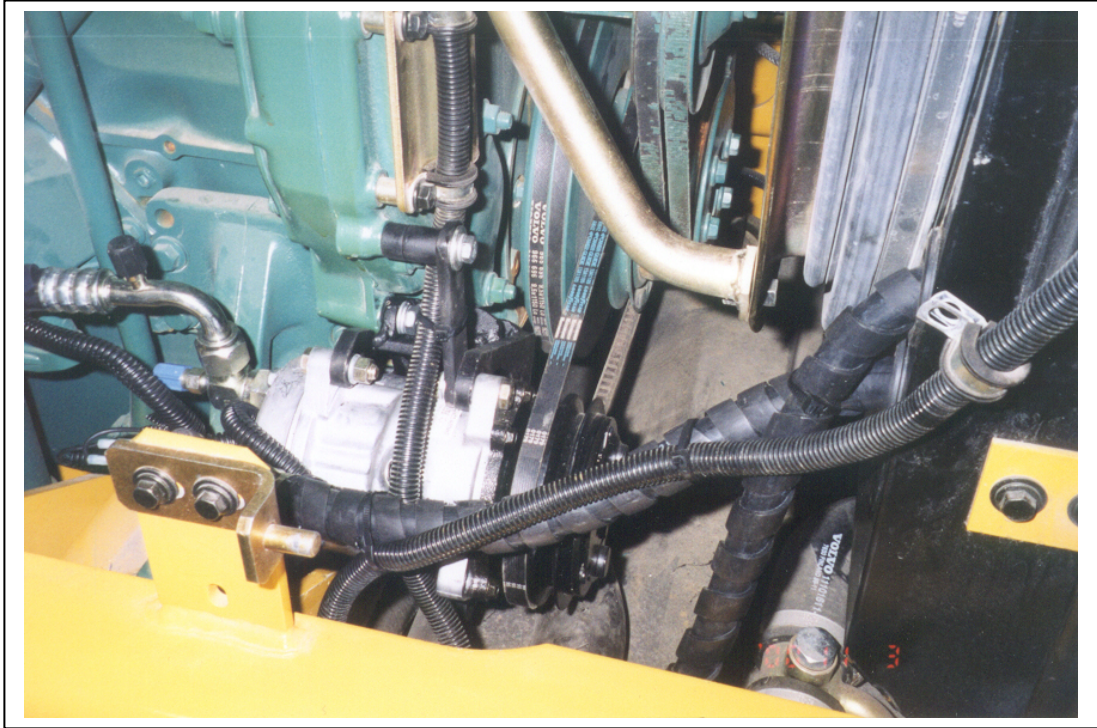

View of compressor in place.

CONDENSER:

The condenser mounts between the engine fan and the radiator. The assembly is hinged to allow for easier access for cleaning and maintenance.

1. Open the external radiator cover and unlatch the radiator. Swing the radiator as far out as it will go and secure in this position.
2. Put the condenser assembly into position on the radiator frame as shown in the pictures and mark the locations for the mounting holes. Drill and tap for ¼” – 20 bolts.
3. Mount the condenser as shown with the fittings on the right (as viewed from the back of the machine. This will make sure the hinged frame is on the left and will not interfere with the hoses and fittings. Make sure the plugs are removed from the holes for the hoses to pass into the engine compartment.

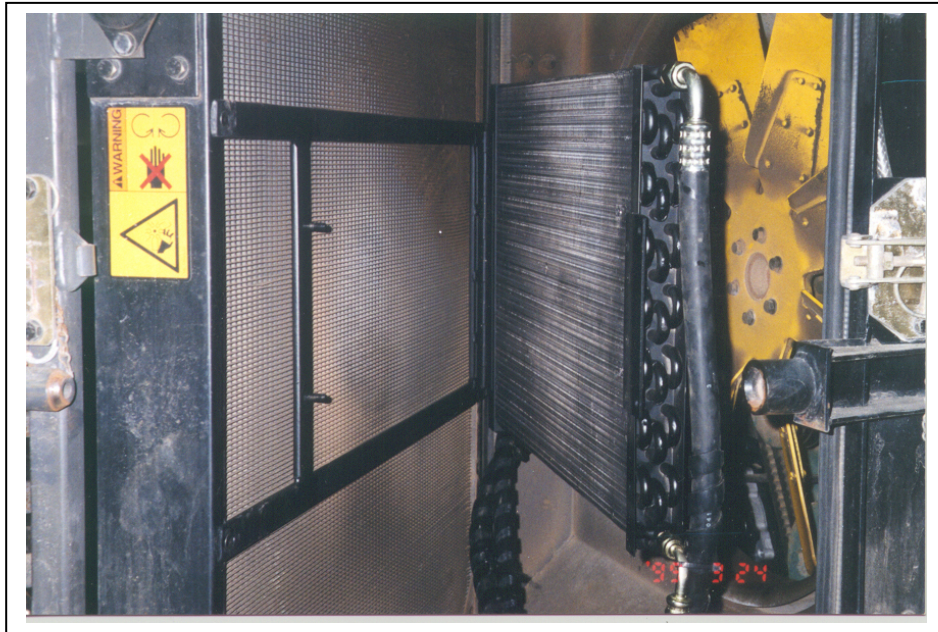

Condenser view showing the mount points and fitting arrangement, with the condenser hinged open.



Condenser view showing the mounting set-up with hoses into engine compartment.

RECEIVER DRIER: (L70C only)

The receiver drier is mounted on a straight bracket on an existing bolt on the left side of the engine.

1. Mount the drier bracket on the existing bolt on the bottom of the flat plate above and ahead of the oil fill cap. Use existing hardware.
2. Mount the drier to the bracket with the two #48 gear clamps provided in the kit. Ensure the 'INLET' fitting on the drier is oriented toward the rear of the machine (away from the cab).

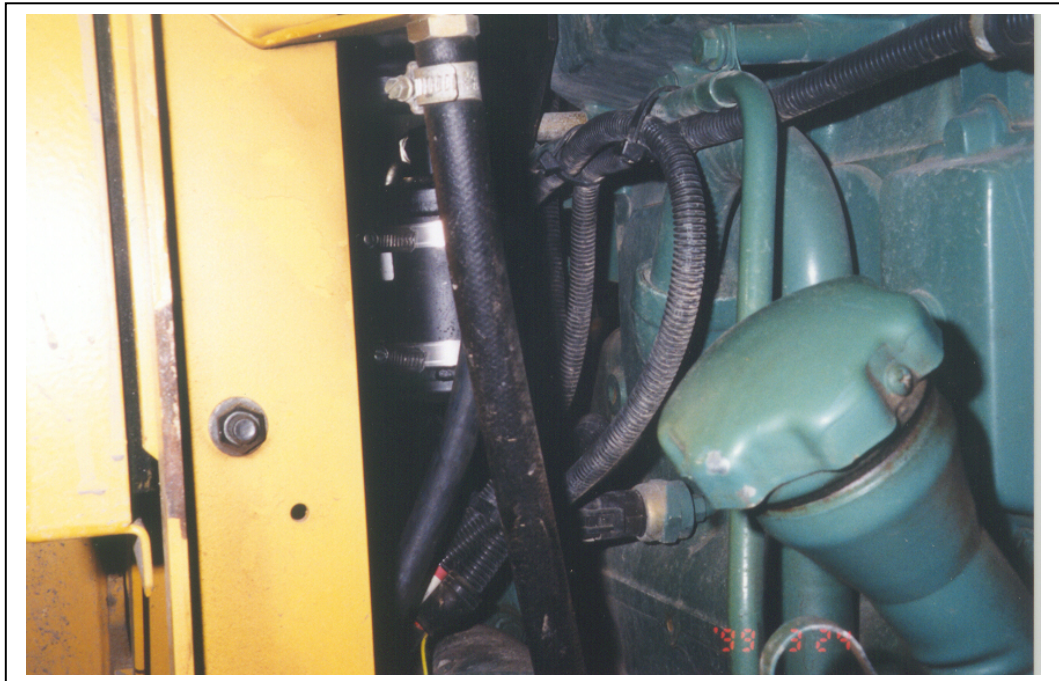

Drier located on engine ahead and above oil fill cap.

L70D DRIER MOUNT

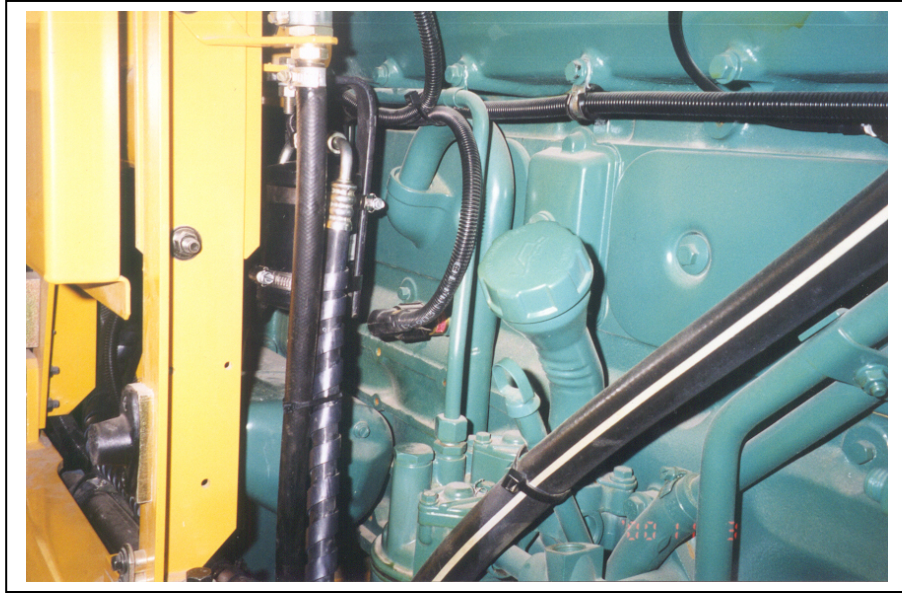

Drier mounted to 90o bracket off existing hole on engine compartment frame

The receiver drier mounts to an existing hole on the engine compartment frame about 8” ahead of the oil fill cap.

1. Bolt the 90o drier bracket to the hole in the frame bracket using the 3/8” hardware provided.
2. Mount the drier to the bracket with the two #48 gear clamps provided in the kit. Ensure the ‘INLET” fitting on the drier is oriented toward the rear of the machine (away from the cab).

ELECTRICAL:

Mount the thermostat on the plastic console directly below the blower switch. Run the probe of the thermostat out and down into the evaporator and insert the probe into the coil as shown in the pictures above. Find the clutch wire running off the blower switch (it will be the wire that is live in any of the 'ON' blower positions and not live when the blowers are 'OFF') and connect to one terminal on the thermostat. Connect the 14ga black clutch wire to the other terminal on the thermostat and route it down out of the heater compartment and along with the suction hose. At the pressure switches, connect the clutch wire to the first press switch lead. Connect the other lead off the first switch to one lead of the second switch. Connect the last lead to the clutch wire on the compressor using the connectors supplied.

In the Volvo Loaders there is an option to use the factory rocker switch to select the air conditioning function. It would be located in one of the open slots on the main panel. The thermostat used in this case could either be a pre-set or a rotary control type. See the wiring diagram for optional arrangements.

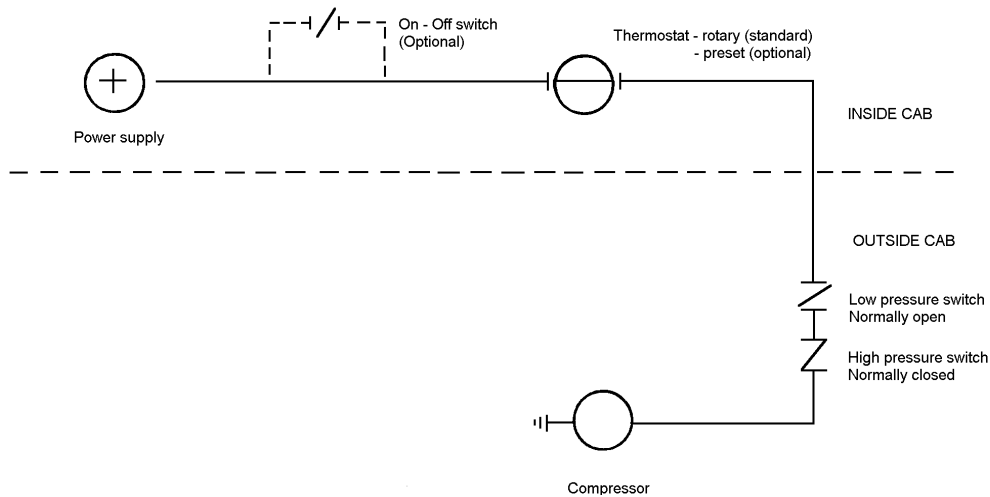

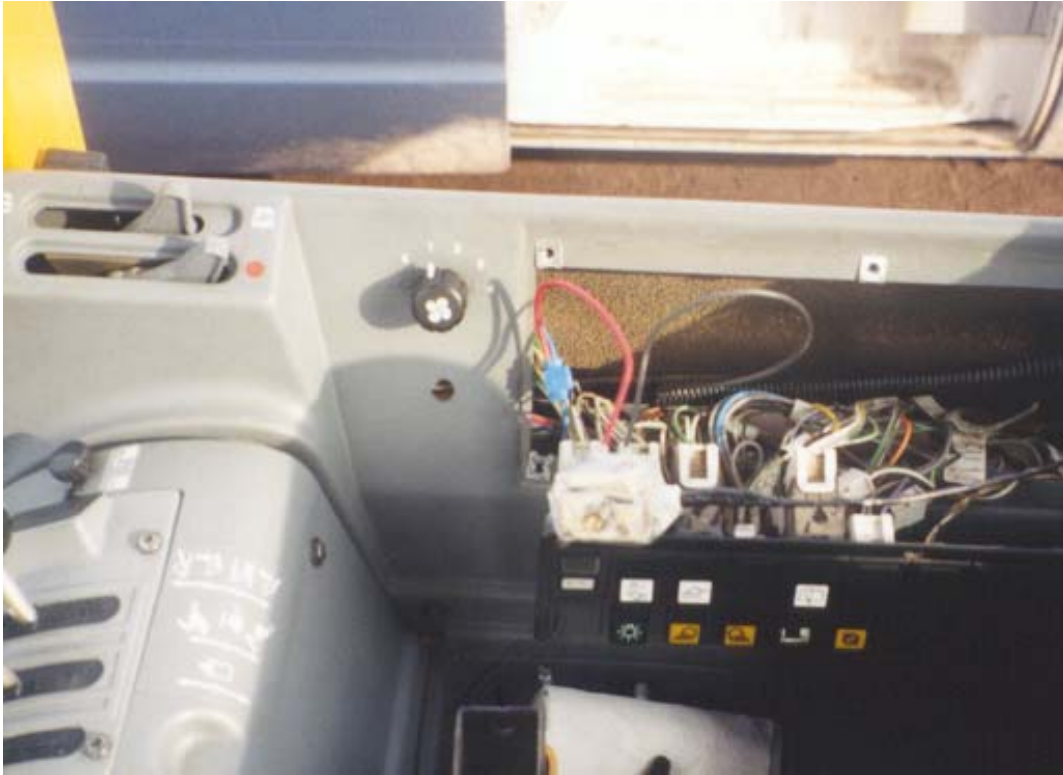

Thermostat and mounting hole below blower switch-on the L70C

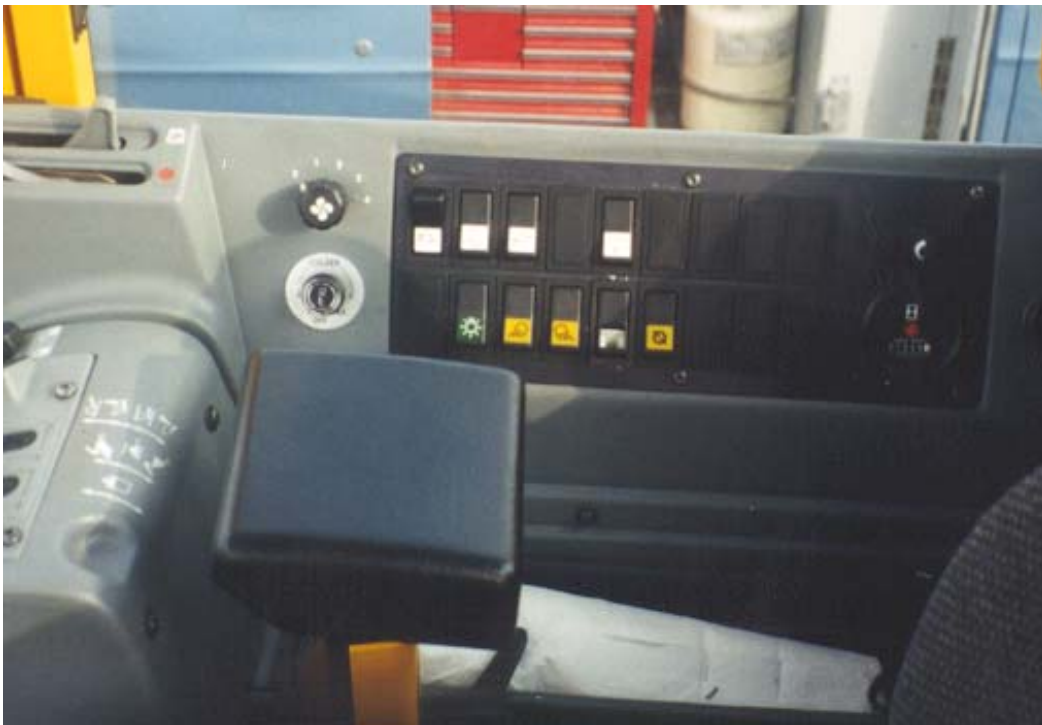

Thermostat mounted in location on the panel the L70C.



Thermostat mounted on L70D

Refrigerant Flow Pattern in a Standard Air Conditioning System

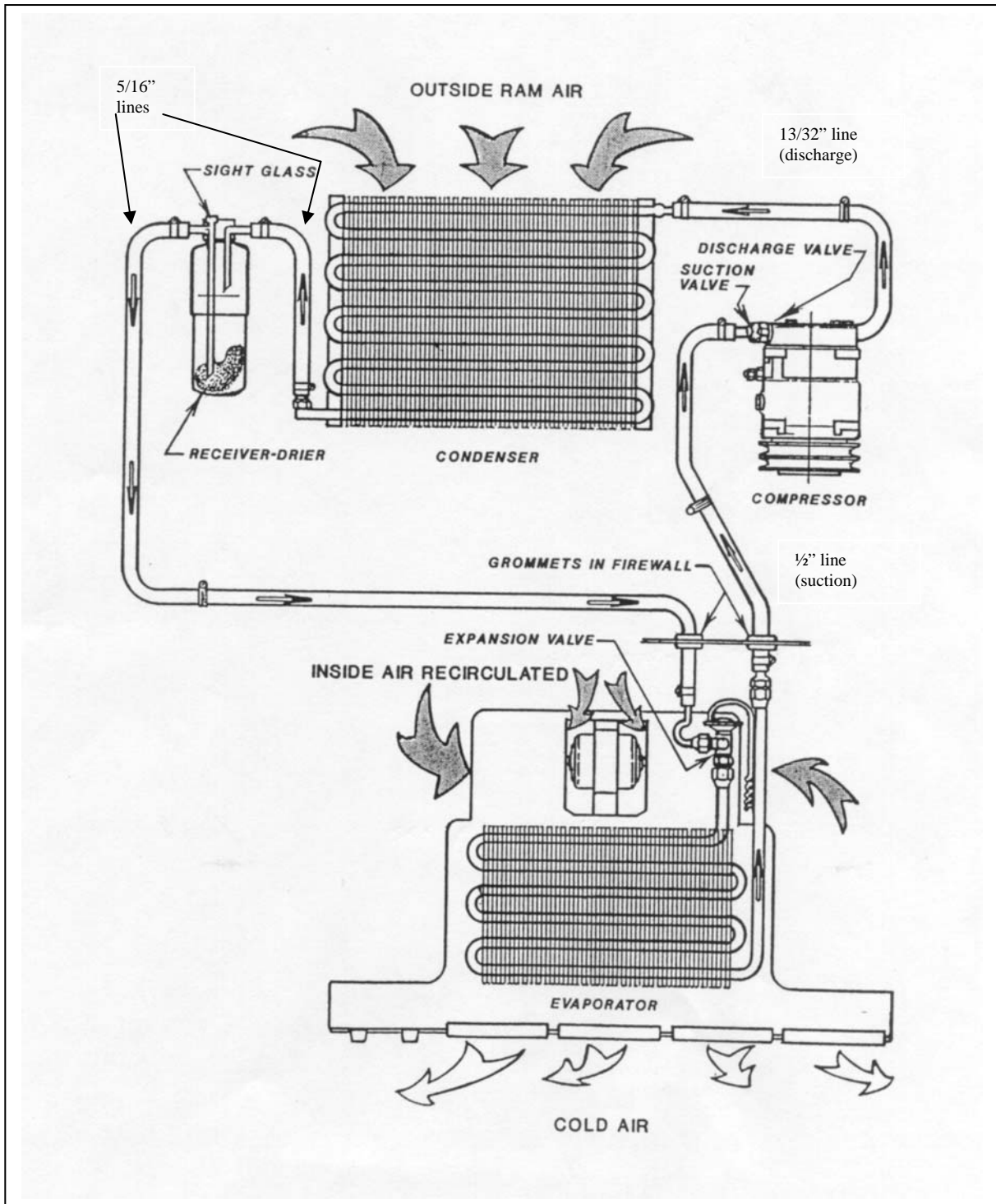

Thermostat Setting Procedures

- 1) Thermostat types
 - a) preset
 - b) adjustable
 - a) A preset thermostat is adjusted to its specific cut in and cut out temperatures when manufactured and does not have a rotary adjustment for the operator.
 - b) An adjustable or rotary thermostat has been manufactured to a predetermined cut in and cut out temperatures, but it is also operator adjustable to achieve the desired comfort level.

Both types of thermostats can have their factory settings adjusted by turning the setting screws on the body of the thermostat. One body type has the setting screws mounted externally and labeled for direction of rotation. The other body type requires the removal of the plastic end plate to expose the set screw.

- 2) Thermostat probe location: The location of the thermostat probe in an evaporator coil can be very important to achieve the maximum cooling potential of the coil while also preventing coil freeze-up. There is no set location for the thermostat probe to be put that will be optimum for all systems, but several rules of thumb may be followed:
 - a) Insert the probe in the coldest area of the evaporator coil.
 - b) Insert the probe from the top of the coil down, if possible.
 - c) Make sure that at least the last 3" of the thermostat probe are in the coil.

To find the most likely area where the coil is the coldest, consider these factors:

- 1) Direction of air flow through the coil.
 - 2) The coil area likely to have the lowest air flow.
 - 3) The inlet locations of the refrigerant into the coil.
 - 4) The inlet of the hotter outside air into the coil area.
-
- 1) Usually the coldest side of the evaporator coil will be the air outlet side. Often the thermostat probe can be inserted between the last and second last row of tubes.
 - 2) The lower air flow area of the evaporator coil in most systems tends to be near either end of the coil. These areas will be colder
 - 3) The area of the coil that the refrigerant inlet tube(s) occupy should be the coldest part of the coil.
 - 4) If the system is equipped with an outside air intake, where and how that air is brought into the evaporator area can have a large effect on the coil temperature. If all the outside air is piped into the evaporator in one area, that area will be considerably warmer in hot weather.

By looking at all these different factors, the area of an evaporator coil most likely to be the coldest can be determined.

Once the probe is inserted, the A/C system needs to be tested. Run the system to ensure that the thermostat is cycling the compressor off at the appropriate temperature. A core temperature ranging between 25° and 30° F should cause the thermostat to cycle off. The air temperature at the vent outlet closest to the evaporator coil should be between 38° F and 45° F when the compressor cycles off.

If the thermostat doesn't cycle off after a reasonable cool down period, and the air outlet temperature has dropped below 40° F, the cut in and cut out settings should be adjusted until the compressor is cycling on and off regularly. Let the system run for a decent time period (at least 15 min) and then check the evaporator coil for any signs of freezing.

Aeroquip E-Z Clip

Assembly Instructions

Step 1. Cut the hose to proper length with an appropriate cutting tool. Aeroquip's hand held hose cutter has been specially designed for cutting all non-wire reinforced hose, such as GH-134 Multi-Refrigerant hose. Be sure the cut is made square to the hose length.

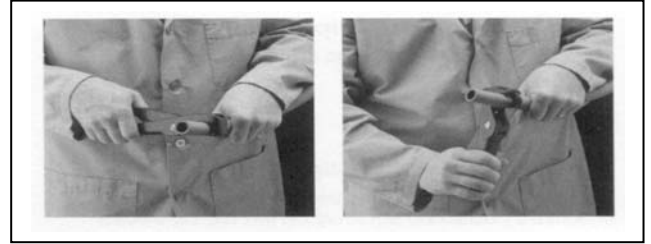

Step 2. Install two proper-sized clips onto the cut end of the hose. Orientation of the clips does not affect the performance of the connection. However, for ease of assembly, both clips should have the same orientation. NOTE: Failure to slide the clips over the hose at this time will require the clips to be stretched over the hose or fitting later. This may permanently damage the clip.

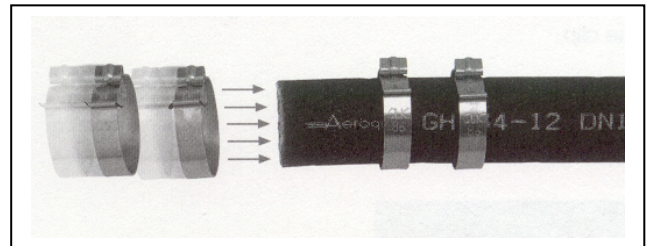

Step 3. Lubricate the nipple with a generous amount of the refrigeration or A/C system's compressor lubricating oil. This MUST be done to lower the force of nipple insertion.

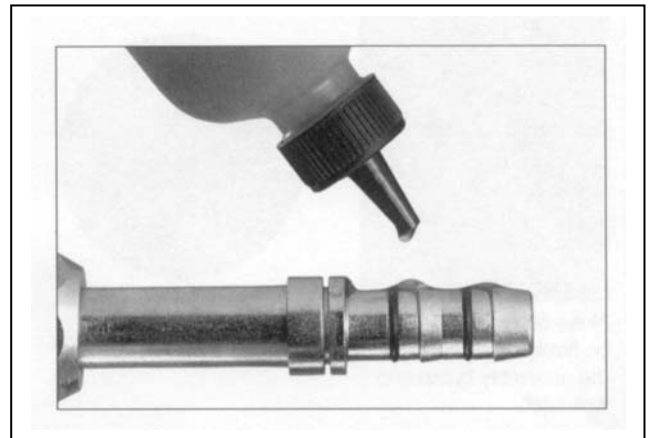

Step 4. Insert the nipple into the hose. To ensure that the nipple is fully inserted, check the gap between the cut end of the hose and the shoulder on the nipple. Care should be taken to avoid kinking or other damage to the hose during nipple insertion. NOTE: Be sure to wipe excess oil from the nipple and hose.



Step 5. Snap the cage into the groove on the nipple. The arms should extend over the



hose length. When the cage has been correctly installed in the cage groove, the cage will be able to rotate in the groove.

This step **MUST** be performed to ensure:

1. The clips will be located over the O-rings on the nipple.
2. The connection will be compatible with the connection's pressure rating.

Step 6. Slide the clips over the cage arms and into the channels on each arm.

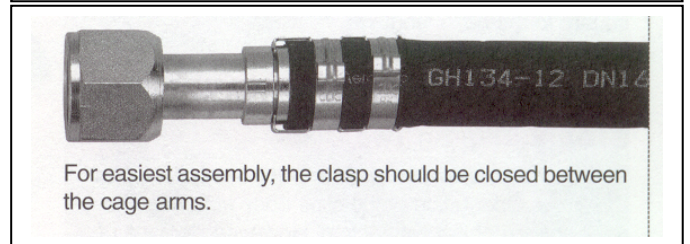
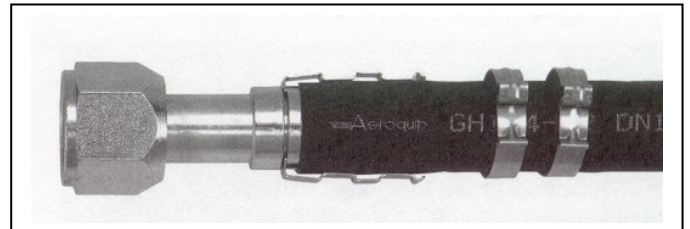

Step 7. Use the pliers to close the clips. The pliers should be positioned squarely on the clip connection points and should remain square during the closing of the clip.

NOTICE: E-Z Clip components should not be reused.

